

# BX22S Weighing Indicator

Industrial indicator with lightning protection



## Standard Features

- Stainless steel, IP67 protected for wet, hygienic & harsh areas
- 25 mm wide angle LCD display with multi-color backlight
- Up to 30 000d display resolution
- Long life Li-ion rechargeable battery

## Lightning & Surge Voltage Protection

- Protected load cell entry
- Protected power line entry
- Galvanically isolated 2 piece RS232C serial interfaces
- Increased EMC immunity

## Typical Applications

- Basic weighing with multiple tare, auto tare, auto clear tare, auto print, unit change, etc.
- Classifying with color changing display at Under, OK and Over, status bar on display, 100 product memories, acoustic warning
- Livestock weighing with smart dynamic weighing algorithm
- Weighbridges against lightning and electrical discharge
- Industrial bench and floor scales in harsh environment



BX22S is a high quality general purpose weighing indicator in stainless steel housing. Its optional alibi memory provides usage with non-approved PC software for approved scales.

BX22SL, the increased lightning & surge voltage protected variant of BX22S, has a very high protection against lightning on its load cell and power supply connections. With its 2 pcs galvanically isolated RS232C ports, BX22SL has important advantage for industrial weighing applications, in particular for weighbridges.

BX22S operation modes; basic weighing, classifying supported with color changing multi-color display and livestock weighing with smart dynamic filter.

With IP67 protected stainless steel housing, BX22S perfectly fits to wet, hygienic and harsh areas. BX22S and BX22SL have re-chargeable Li-ion long life battery.

**BAYKON**  
Industrial Weighing Systems

# BX22S Specifications

Accuracy	OIML R76 Class III																																					
EU type approval	6.000 intervals (single range) or 2 x 6000 intervals (multi range)																																					
Resolution	16 000 000 internal, up to 30 000d display resolution																																					
Weighing units	g, kg, oz, lb																																					
Unit change	g-oz and kg-lb change by pressing programmed function key																																					
Display	112 x 40 mm extra wide angle multi color backlighted LCD with 25 mm digit height																																					
Buzzer	Different buzzer mode to warn the operator at classifying																																					
Auto power off	Programmable for saving battery life																																					
Taring	Multiple, automatic and tare-clear in sequence																																					
Filter	Very low, low, medium high and very high																																					
G/N selection	If enabled, G/N indication by pressing function key																																					
Totalizing	Yes																																					
<b>Classifying</b>																																						
Product memory size	100 different products																																					
Operator prompting	Under, OK, Over status bars on multi color display and programmable buzzer																																					
<b>Dynamic Weighing</b>																																						
Animal weighing	Supported by smart dynamic weighing algorithms																																					
EMC protection	BX22S	According to OIML R76 and related EMC standards																																				
	BX22SL	Increased lightning protections of load cell, serial ports and power supply connection. RS-232C serial ports are galvanically isolated																																				
Interface	BX22S	2 pieces RS-232C serial ports																																				
	BX22SL	2 pieces galvanically isolated RS-232C serial ports																																				
Alibi memory	65 000 weighing records (optional)																																					
Data output	Programable as continuous or various weighing ticket format																																					
Date format	Programable to dd.mm.yyyy, mm.dd.yyyy or yyyy.mm.dd																																					
Printout language	English, French, German, Spanish and Turkish																																					
Weighing ticket samples	<table border="1" style="width: 100%; text-align: center;"> <thead> <tr> <th colspan="2">Weighing</th> <th colspan="2">Dynamic Weighing</th> <th colspan="2">Classifying</th> </tr> </thead> <tbody> <tr> <td>Weighing number</td> <td>#000010</td> <td>Weighing number</td> <td>#000014</td> <td>Weighing number</td> <td>#000024</td> </tr> <tr> <td>15-09-2012</td> <td>01:04:03</td> <td>15-09-2012</td> <td>01:08:57</td> <td>15-09-2012</td> <td>01:24:06</td> </tr> <tr> <td>Gross</td> <td>4.771 kg</td> <td>Dyn Gross</td> <td>4.771 kg</td> <td>Gross</td> <td>1.705 kg</td> </tr> <tr> <td>Tare</td> <td>1.675 kg</td> <td>Tare</td> <td>1.675 kg</td> <td>Tare</td> <td>1.675 kg</td> </tr> <tr> <td>Net</td> <td>3.097 kg</td> <td>Dyn Net</td> <td>3.096 kg</td> <td>Net</td> <td>0.030 kg OK</td> </tr> </tbody> </table>		Weighing		Dynamic Weighing		Classifying		Weighing number	#000010	Weighing number	#000014	Weighing number	#000024	15-09-2012	01:04:03	15-09-2012	01:08:57	15-09-2012	01:24:06	Gross	4.771 kg	Dyn Gross	4.771 kg	Gross	1.705 kg	Tare	1.675 kg	Tare	1.675 kg	Tare	1.675 kg	Net	3.097 kg	Dyn Net	3.096 kg	Net	0.030 kg OK
Weighing		Dynamic Weighing		Classifying																																		
Weighing number	#000010	Weighing number	#000014	Weighing number	#000024																																	
15-09-2012	01:04:03	15-09-2012	01:08:57	15-09-2012	01:24:06																																	
Gross	4.771 kg	Dyn Gross	4.771 kg	Gross	1.705 kg																																	
Tare	1.675 kg	Tare	1.675 kg	Tare	1.675 kg																																	
Net	3.097 kg	Dyn Net	3.096 kg	Net	0.030 kg OK																																	
Housing	Stainless steel, IP67, 224X134 mm																																					
Mounting accessories	Wall mount accessory is available as standard																																					
Battery	2000 mAh Li-ion, up to 36 hours continuous operation for single load cell, 24 hours continuous operation for 4x350 Ohm load cells																																					
Power	100-240 VAC, 50-60 Hz, optional 12 VDC input																																					

## Dimensions (mm)

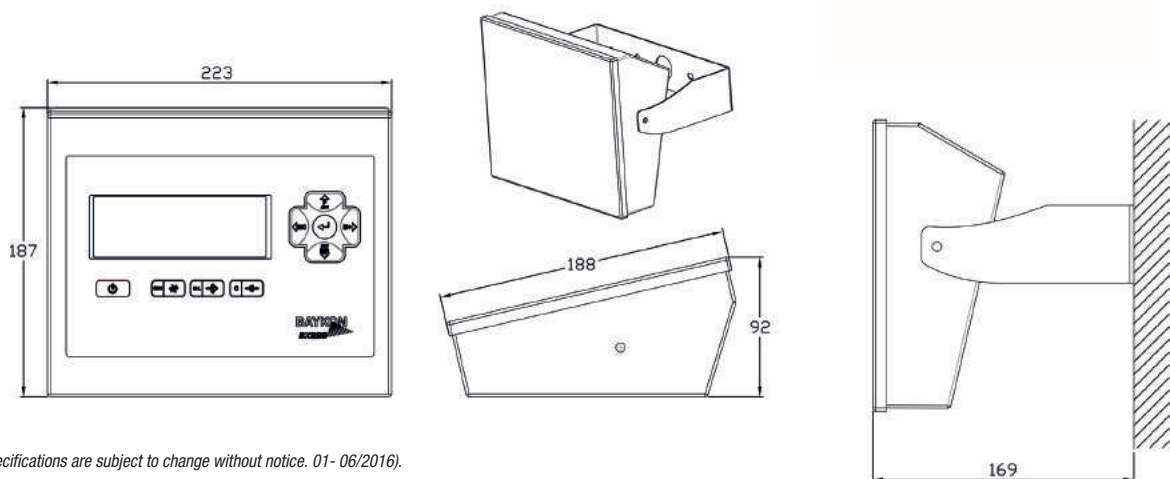

(Features and specifications are subject to change without notice. 01- 06/2016).