

BX30 Fill - Filling Controller

Smart Controller for Filling and Packing Machines



Main Features

- 12 different operation modes for the most common applications,
- Configurable recipe content,
- 7 Programmable keys,
- Digital I/O's: Internal 12/14, external 16/16
- Spare I/O's to continue filling in case of any digital I/O malfunction.



Smart Operation with

- Smart filling algorithms,
- Smart start-up the filling.
- Full control of bagging machines,
- Master-slave operation to transfer set-up to other instruments,
- Multicolor LCD to guide and warn the operator.



Advanced Technology & Performance

- High speed real time operation,
- Up to 1600 conversions per second,
- 1000 times higher filling control resolution than scale increment,
- Freely programmable digital I/O's, timers and logic functions,
- Remote service via internet.



Integration & Connectivity

- Ethernet TCP/IP, USB, RS-232C, RS-485, Profibus, Profinet, Modbus RTU, Modbus TCP, EtherNet/IP, EtherCAT, CANopen, CC-Link, CC-Link IE, Powerlink
- DIN rail digital I/O unit for easy cabling in the cabinet.



BX30 Fill, filling and packing controller is high tech, smart and economic instrument for usage at various filling and packing machines. Its configurable specific recipe build feature and smart filling algorithms give big advantages in usage.

The most common filling & packing applications fit one of its 12 filling modes. Master-slave operation provides the set up and recipe transferring to all BX30 Fill slave controllers on the machine. Full control of multiscale bagging or packing machine is available.

BX30 Fill has Recipe and ID memories having 250 records size each, for fillings with different materials and specific fillings like batch filling.

Its programmable 7 keys can be assigned to the predefined functions in order to provide quick and informative operation. Freely programmable digital inputs and outputs eliminates additional PLC requirement in the cabinet to control customers pump, pilot valve, nitrogen purging, rotary valve, bag inflator, material activator etc.

Programmable reserved I/O ports enable operation until receiving the new digital I/O board in case of any digital I/O malfunction.

BAYKON
Industrial Weighing Systems

High accuracy at fast filling applications with BAYKON technology and know-how.

BX30 Fill is new generation filling controller developed with Baykon state of the art technology and know-how. It is developed to use at all kinds of gravimetric filling, dosing and packaging applications for powder and liquid fillings. With its advanced and intelligent electronic technologies, BX30 Fill meets all your requirements from basic filling machines to the most complex packaging machines. Integration of BX30 Fill to the factory automation system - like e PC / PLC / Scada etc. - is very simple!

SmartAPP

This a special function which helps the operator to follow the operation on the display by changing the display color and the analogue bar graph. The Smart adjustment technics and a the Smart start-up are its additional advantages at filling & packing.

Changing Display Colour



Filling in progress



Under



Okay



Over



Error

Bar Graph

Operator may follow the filling on the bar graph



Acoustic warning

The filling controller produces key sound at pressing keys. Additionally, the acoustic alarm warns the operator in case of hardware, scale and weighing related errors.

Identification and Memory

Recipe and ID memories. Each has 250 records size for fillings of various materials.



Functional Keys

Five user programmable function keys, change key and magnify key can be set to specified functions for your easy and informative usage.



Filling Modes

- ✓ Open container filling
- ✓ Bung - hole type container filling
- ✓ Filling from bottom of the container with lance control
- ✓ Packing
- ✓ Bag filling
- ✓ Big bag filling
- ✓ Valve bag filling machine
- ✓ Bagging machine with single weighing hopper
- ✓ Bagging machine with up to 16 weighing hoppers
- ✓ Packing machine with up to 16 weighing hoppers
- ✓ Filling container from tank scale
- ✓ Weigh in - Weigh out

Digital Inputs and Outputs

In-house digital I/O board or DIN rail mount, RIO16 digital I/O unit.

In-house Digital I/O

RIO16
DIN rail mount
Digital I/O unit



PLC Interfaces :

- Profibus
- Profinet
- Modbus RTU
- Modbus TCP
- EtherNet/IP
- EtherCAT
- CANopen
- CC-Link
- CC-Link IE
- Powerlink
- Digital I/O



Standard Interfaces :

- Ethernet TCP/IP
 - USB
 - RS 232C (isolated)
 - RS 485 (isolated)
- for PC, Printer, Barcode reader, remote display etc.

Load Cell Connection

- ✓ Analogue load cell (BX30 Fill)



Applications Samples

Open Container Filling

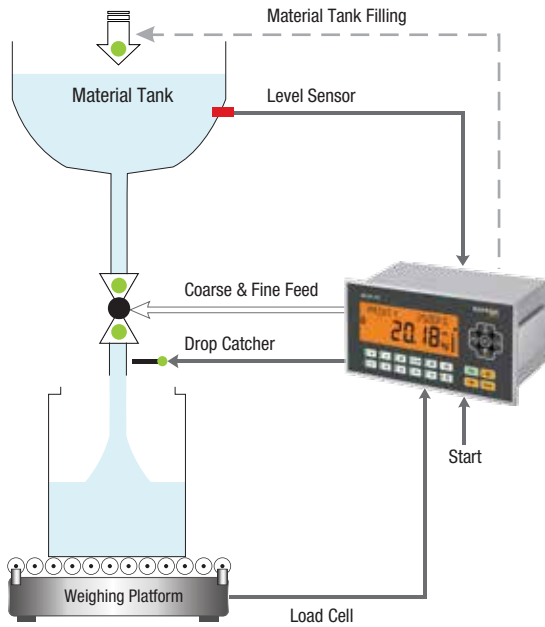

Bung Hole Type Container Filling

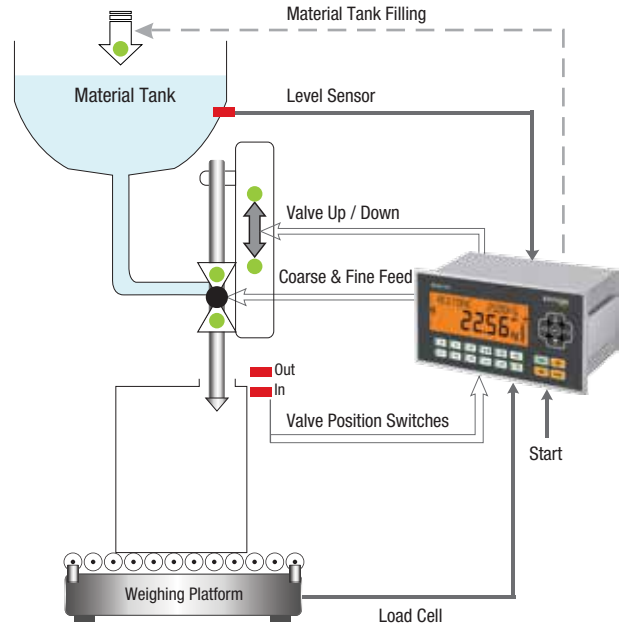

Container Filling from Bottom, In or Above surface

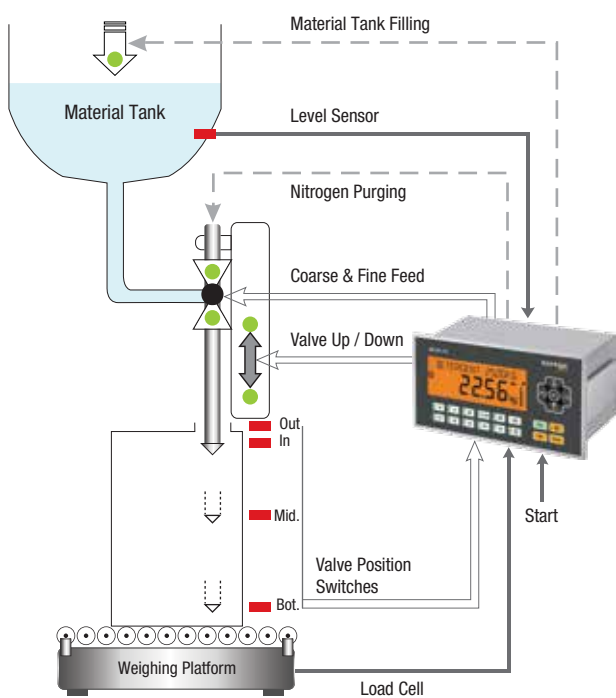

Pallet Filling in High resolution (200 kg x 0,1 kg)

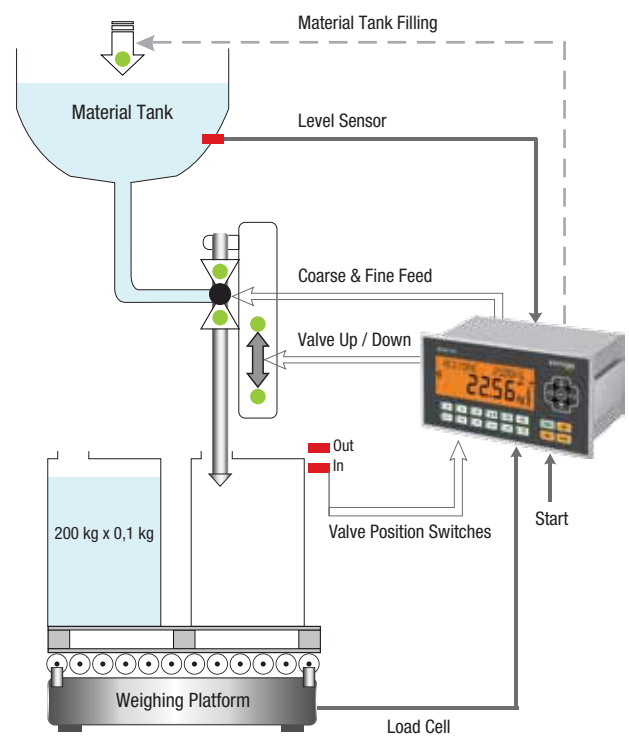

Filling Machine with Lifter

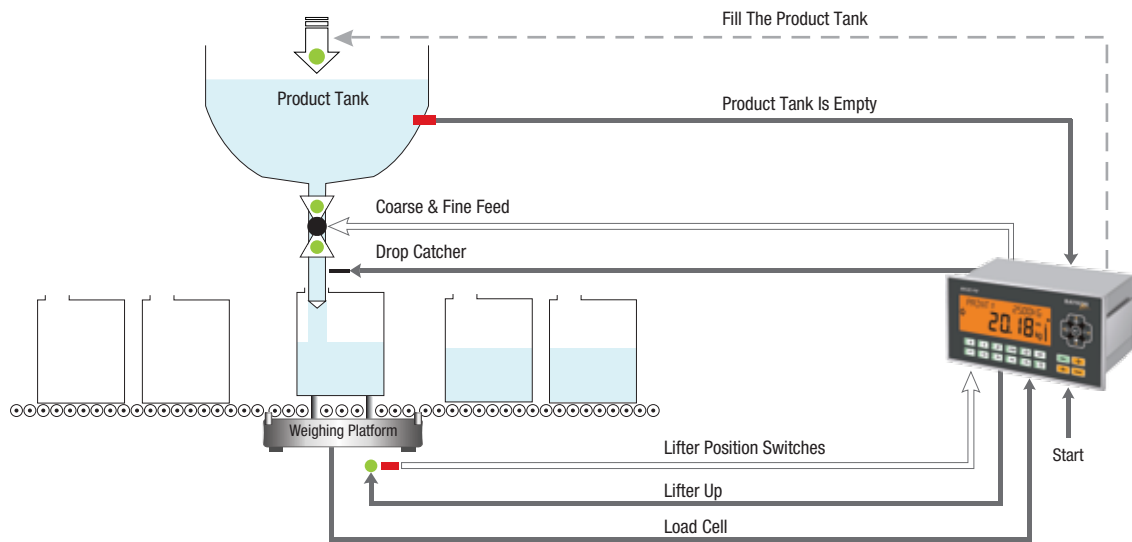

Master Slave Interface at Rotating Filling Machine

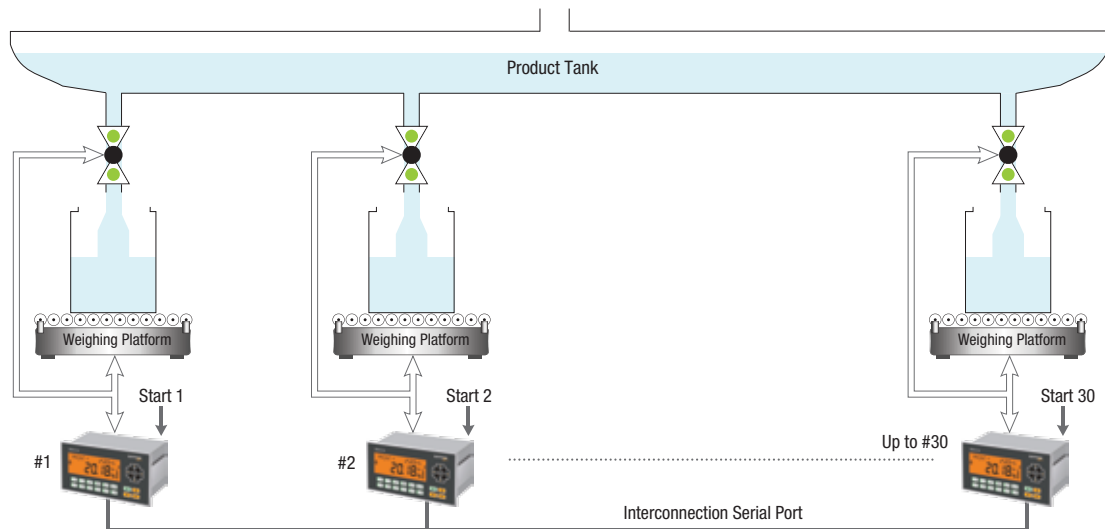

Filling from the Tank Scale

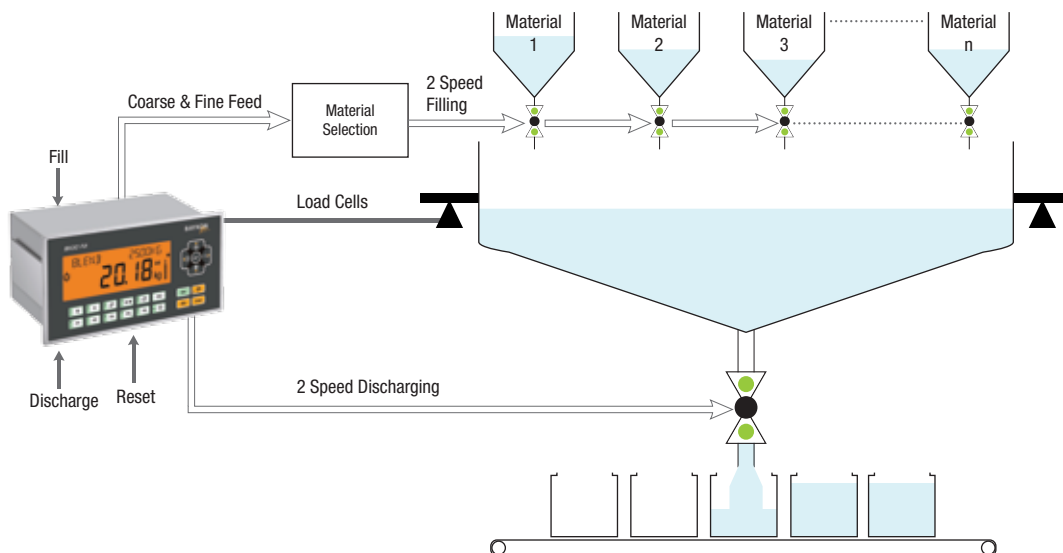

Applications Samples

Bagging

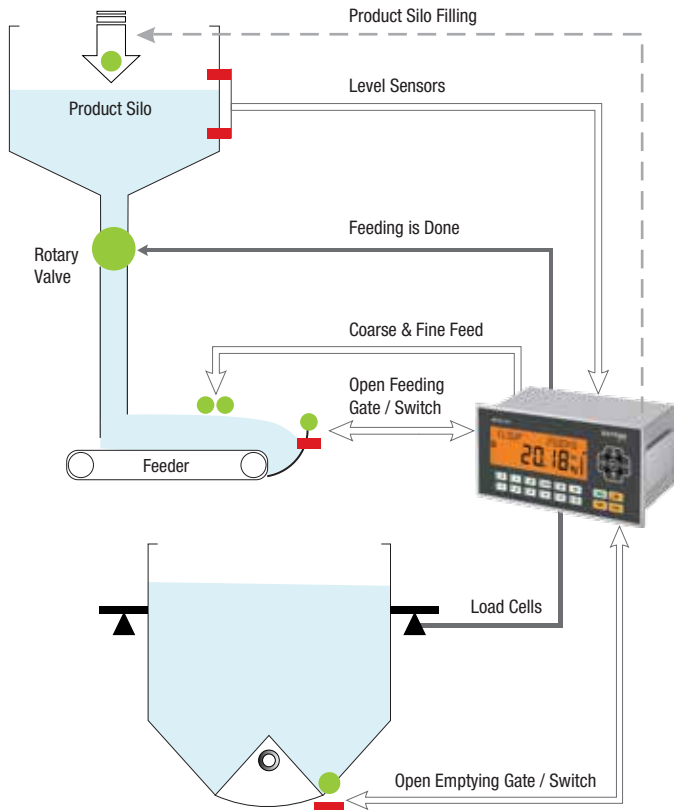

Packing

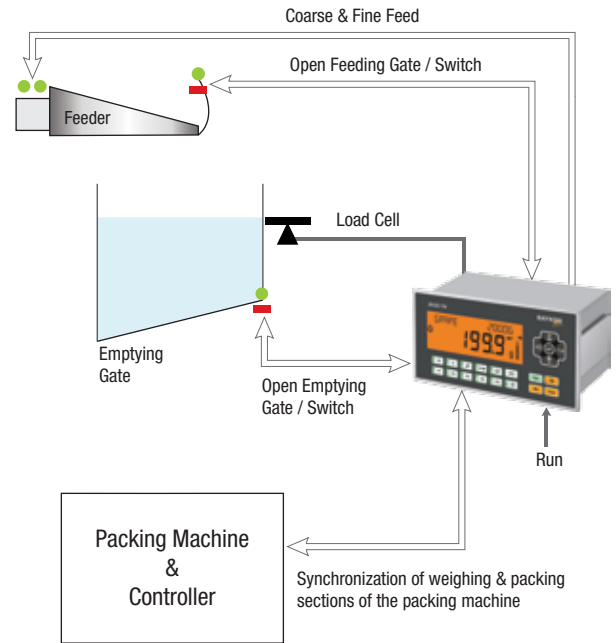

Big Bag

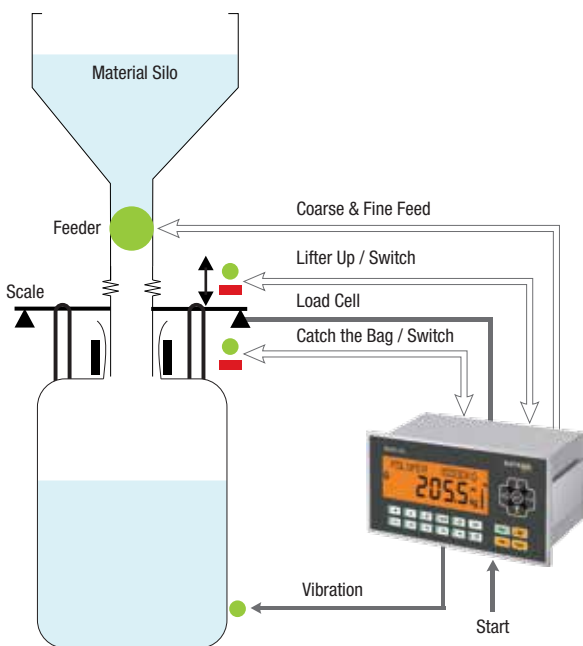

Weigh-in / Weigh-out

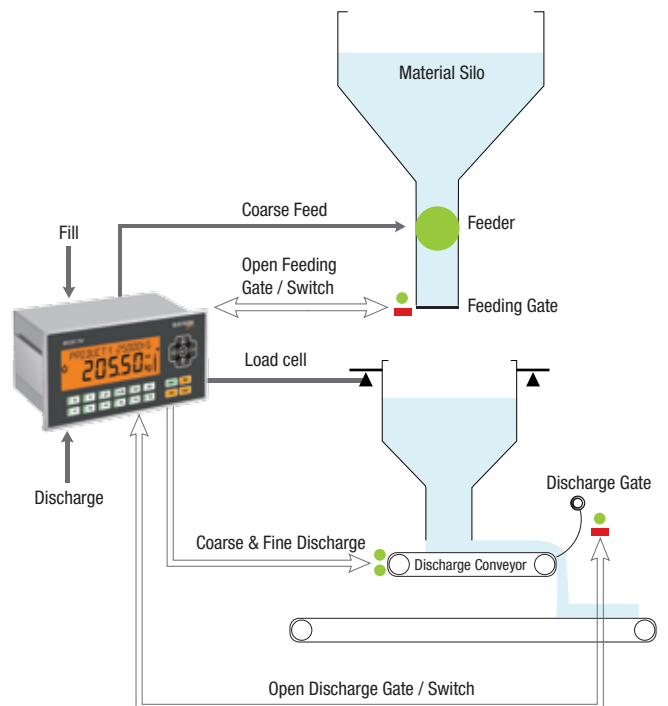

Bagging Machine with Single Scale

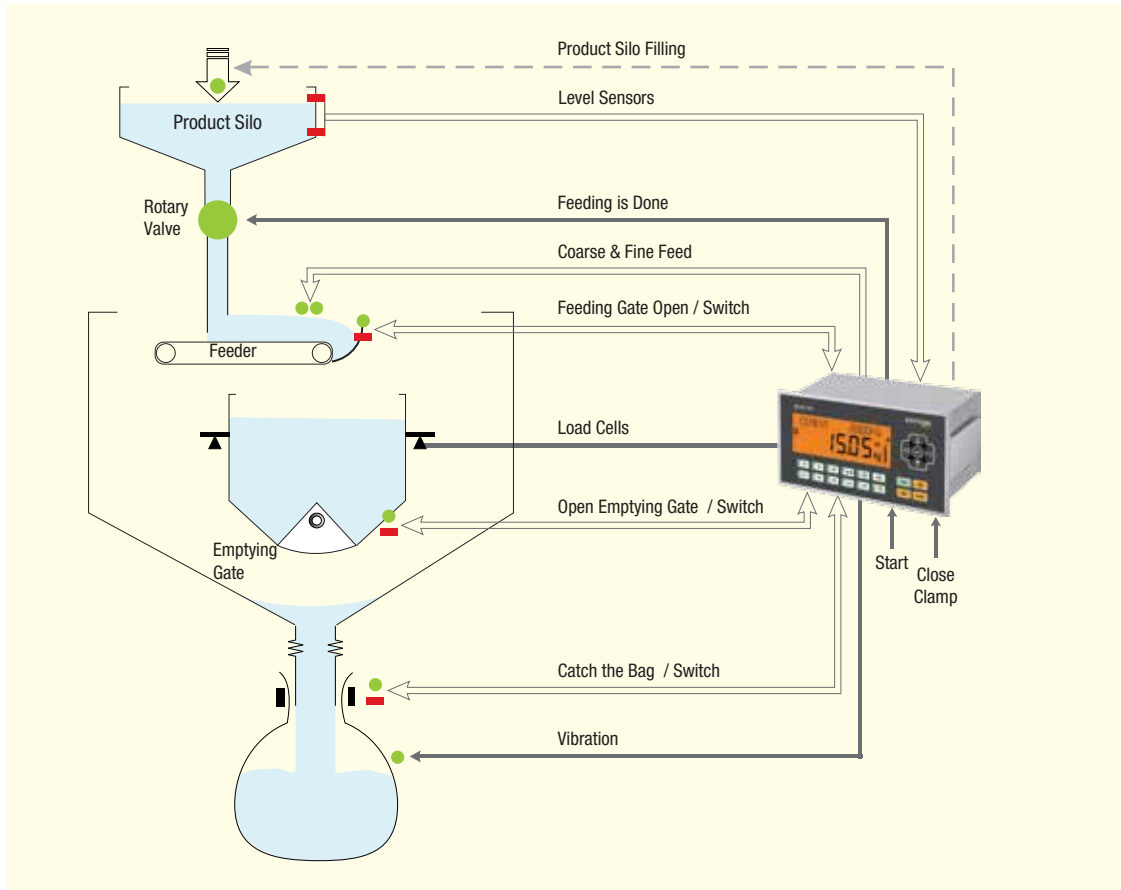

Bagging Machine with Double Scales

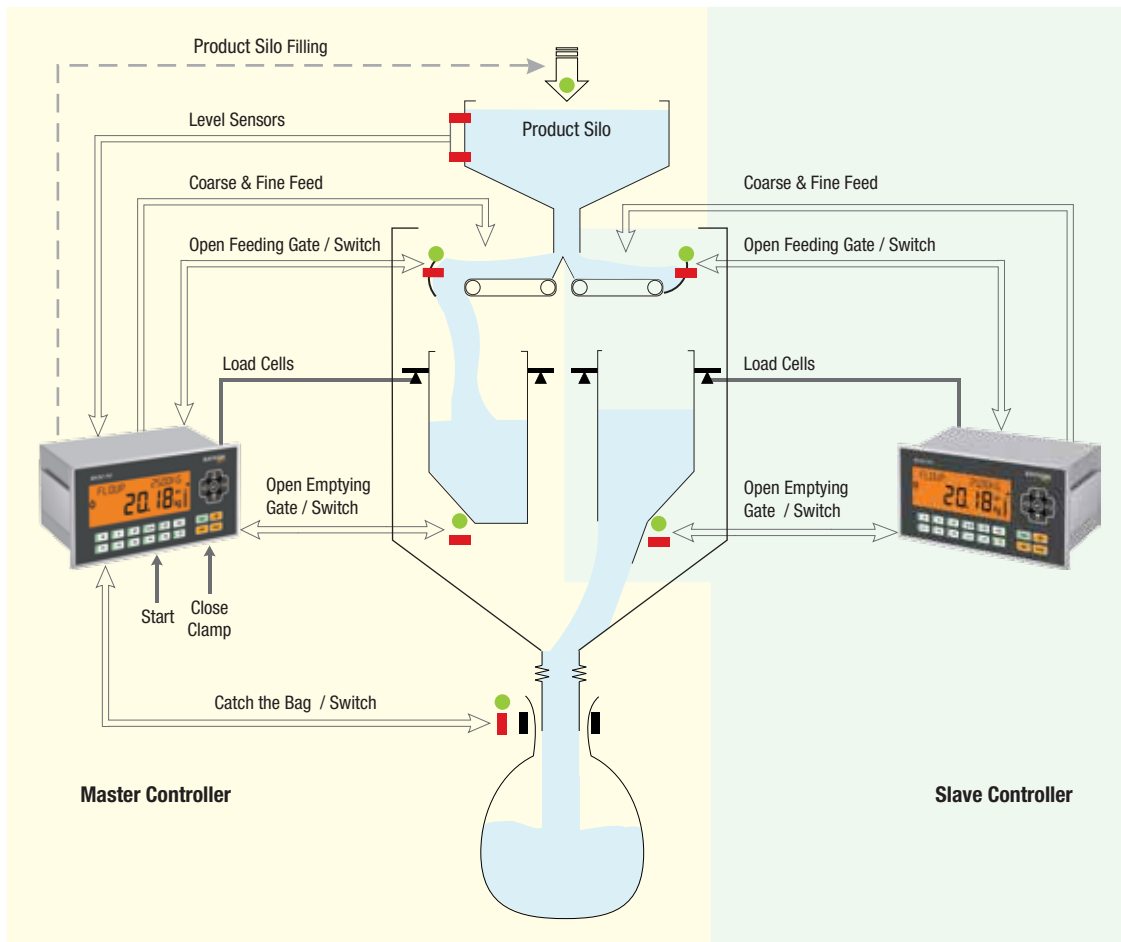

Technical Specifications

Model	BX30 Fill
Accuracy class & EU type approval	OIML class III, single range, multi range or multi interval up to 10000 divisions.
Display	Wide angle and bright LCD display with multicolor backlight, 22 mm in height 6 digits weight display and 8 mm in height 16 digits alphanumeric information display.
Display resolution	Up to 300 000 divisions at industrial usage.
A/D conversion	24 bit Delta-Sigma ADC with up to 1600 conversions rate.
Minimum input sensitivity	0.4 $\mu\text{V/e}$ (legal metrology), 0.05 $\mu\text{V/d}$ (industrial)
Analogue input range	-5 mV to +19 mV
Internal resolution	Up to 16 000 000 counts.
Calibration	Calibration with test weights, eCal-electronic calibration without test weights, Span calibration with temporary zero of charged tank, Zero adjustment, Gain adjustment, Coefficient entry.
Digital filter	7 steps programmable adaptive filter.
Scale functions	Taring, zeroing, auto zero tracking, motion detection, auto zero at power up, tare status save at power off, increased resolution, automatic tare and clear, temporary gross indication, unit change.
Filling modes	12 different packing / filling modes with smart filling algorithms.
Memory	Two memories for recipe and ID , each has 250 records size.
Programmable keys	7 programmable keys to assign specific functions.
Digital I/O	Internal: 12 digital inputs / 14 digital outputs External: 16 digital inputs / 16 digital outputs with DIN rail mounting RIO16 unit.
Digital inputs	Opto-isolated and reverse polarity connectable, 12 to 28 VDC, 10mA. Selectable input(s) can be programmed as logic and time functions or used as a Remote Input of your PLC over Fieldbus.
Digital outputs	Opto-isolated and short circuit protected transistor outputs, 12 to 28 VDC / 100 mA, Selectable output(s) can be programmed as logic and time functions or used as a Remote Output of your PLC over Fieldbus.
Data outputs	Galvanically isolated RS232C, RS485, USB and Ethernet TCP/IP
Fieldbus interface	Profibus, Profinet, CANopen, Modbus TCP, Modbus RTU, Ethernet TCP/IP, EtherNet/IP, EtherCAT, CC-Link, Powerlink
Number of load cells	Up to 8 load cells 350 Ω or up to 26 load cells 1200 Ω (min. 43 Ω)
Load cell connection	Connection with 4 or 6 wires. Cable with 6 wires length maximum 1000 m/mm ²
Load cell supply voltage	5 VDC @ max. 150 mA
Operation temperature	-15°C ~ +55°C max. (Operational), -10°C ~ +40°C (Legal metrology)
Humidity	Max. 90 % non-condensing relative humidity. For legal metrology max. 80 %
Alibi memory	99 999 weighing records.
Housing and protection class	IP67 protected stainless steel front panel, aluminum body and stainless steel rear panel.
Power supply	12 – 28 VDC 100mA@24 VDC (Basic instrument)
Dimensions (H x W x D)	108 x 205 x 112,5 mm Panel mount cutout dimensions (H x W): 92 x 186 mm
Gross weight	1,75 kg

Ordering & Interface Selection Table

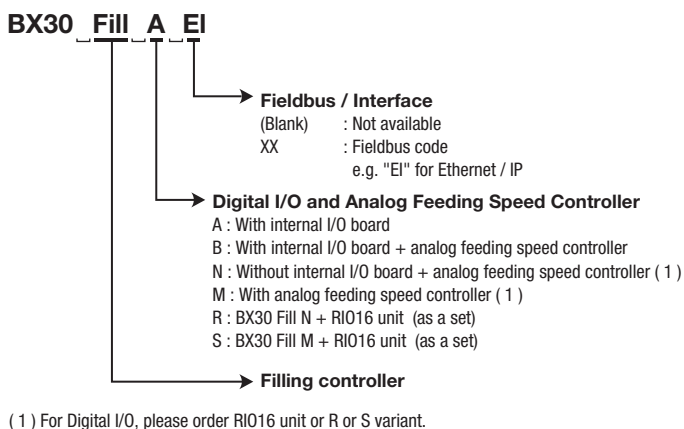

	BX30 Fill A	BX30 Fill A PB	BX30 Fill A CO	BX30 Fill A CC	BX30 Fill A PN	BX30 Fill A EI	BX30 Fill A EC	BX30 Fill A PL	BX30 Fill A IE
RS232C	●	●	●	●	●	●	●	●	●
RS485	●	●	●	●	●	●	●	●	●
RS422	●	●	●	●	●	●	●	●	●
USB	●	●	●	●	●	●	●	●	●
Ethernet TCP/IP	●	●	●	●	●	●	●	●	●
Modbus RTU	●	●	●	●	●	●	●	●	●
Modbus TCP	●	●	●	●	●	●	●	●	●
Profibus DPV1		●							
CANopen			●						
CC-Link				●					
Profinet					●				
EtherNet/IP						●			
EtherCAT							●		
Powerlink								●	
CC-Link IE									●
Alibi Memory	○	○	○	○	○	○	○	○	○

● Standard ○ Optional

Note: Order code is arranged in the same way for BX30 Fill B, M, N, R, and S variants too.
 e.g.: BX30 Fill B PB / BX30 Fill N CC / BX30 Fill M IE / BX30 Fill S EC